



HYDRAULIC EXCAVATORS

CX350B-CX370B



Engine Horsepower	CX350B 202 kW - 275 hp	CX370B 202 kW - 275 hp
Operating weight	34.2 t	36.2 t
Bucket capacity	0.74 m ³ to 2.01 m ³	0.74 m ³ to 2.01 m ³

P R O F E S S I O N A L P A R T N E R

POWER PERFORMER

Tier III common rail engine combines fuel efficiency and low emissions with increased power. Working with advanced hydraulic control results in significant fuel savings, cutting ownership costs and boosting tonne per litre productivity.

Three working modes match power and speed to every application. Increased digging forces available with advanced Auto mode and Super Power mode. Increased digging forces, rapid slew speeds and high swing torque result in faster cycle times and increased profitability.

High Output. Reduced Cost.

OPERATOR SECURITY

New Case cab structure is three times stronger, yet has increased glass area and reduced profile pillars for improved visibility all round, increasing safety for the operator and the job site. Single window to the operator's right offers excellent view to the tracks and across the machine. Easy to read operating console and shorter joysticks with increased controllability reduce operator fatigue and boost productivity. Hose burst control valves are standard on boom and dipper cylinders, to further increase safety on the machine.

Improved Visibility. Maximum Safety.



MODERN DESIGN

Variable pump torque control works with advanced engine throttle and hydraulic mode selection system to boost productivity with reduced operator effort. Exhaust gas recirculation (EGR) helps the engine to meet Tier III emissions regulations, resulting in lower fuel consumption and improving the environment for all. Structured component layout assists ease of maintenance. Super Fine synthetic filter allows up to 5,000 hour hydraulic oil change intervals, reducing downtime and operating cost. Redesigned boom and dipper arm increase strength and durability, while all electronic components have waterproofed connectors for ultimate reliability.

Environmental Responsibility. Added Durability.

DESIGNED TO WORK

Revised cab design provides additional 60 mm of leg and foot space and the cab benefits from a significant 60 % increase in glazed area, further contributing to the light and spacious feeling for the operator. A reclining seat and air conditioning with multiple vents are standard, allowing any operator to remain comfortable throughout the working day. The temperature controlled cab is mounted on viscous fluid cab mountings to reduce vibration and internal noise levels. With smooth intuitive controls and improved ergonomics, this contributes to increased comfort and reduced operator stress. In-cab storage includes a cold box for drinks, a cup holder, a mobile phone pocket and a large storage compartment behind the operator's seat.

Operator Approval. Increased Productivity.

RELIABLE AND DURABLE

Case excavators have long been known for their inherent durability and the strength of their components. A robust upper structure and revised boom and dipper design with forged brackets offer increased strength and reliability, in line with the higher performance of the CX350B. An outstanding undercarriage design provides high stability for maximum digging performance. EMS bushes further increase durability, reducing ownership costs and boosting working time in arduous operating conditions. A high performance synthetic fibre hydraulic filter protects components, with no need for separate filters when the machine is used with a hydraulic breaker. All electronic harness connectors are waterproofed and the centralised electric system is installed in a clean area behind the cab.

Reduced Downtime. Reliable Performance.



ECONOMIC PRODUCTIVITY

The CX350B benefits from a larger fuel tank with a high flow auto stop refuelling pump as standard. Combined with the Tier III engine's reduced fuel consumption and the highly efficient hydraulic system, this results in longer working periods between refills, boosting productivity. Easy to maintain coolers, mounted side by side, and ground access centralised filter bank reduces service time, keeping your machine working. Extended Maintenance System (EMS) bushes offer 1,000 hour greasing intervals on the majority of pins, reducing downtime, while low friction resin side shims on the boom and dipper pins reduce wear and increase operator comfort through smoother operation. The CX350B uses the same buckets as the previous generation of machines, enabling rapid acceptance into a fleet. Operators can also preset up to 10 auxiliary pressure and flow settings, allowing rapid change of attachments for increased versatility.

Lower Operating Cost. Higher Profitability.



Six cylinder Tier III engine features high pressure common rail and is already well prepared for the future move to Euro IV emissions standards. Low speed with high torque design, offering 202 kW and a mighty 1.080 Nm, provides unstressed performance for longevity and reliability. Low engine speed contributes to lower noise output and improvements in fuel consumption and reduced emissions. Large capacity exhaust muffler and large diameter engine cooling fan further reduce engine noise.

Standard fuel cooler helps to reduce fuel consumption, while four valve per cylinder engine design, using advanced exhaust gas recirculation (EGR) reduces gaseous emissions. Auto and one-touch idle speed allows the operator to control the engine for maximum efficiency.



The CX350B shares the powerful Case heritage of excavator design. The machine is equipped with two highly efficient piston type pumps to maximise pressure and flow. These are controlled by a variable control pump torque system that matches engine output to hydraulic demand, ensuring high productivity by rapidly reacting to servo lever movement. High swing torque and increased slew speed result in reduced cycle times in repetitive loading operations. A high performance Super Fine synthetic fibre hydraulic filter ensures a high contamination catch, protecting valuable components and prolonging oil service life to 5,000 hours. When the machine is used with a hydraulic breaker there is now no need for additional filters to be used, cutting operating cost for the customer. Standard hose burst control valves are mounted behind the main lift cylinders, for improved protection and increased safety on site.



The fully adjustable right hand console includes the machine's advanced engine throttle control, enabling working mode selection. A luminosity sensor in the console display ensures that the graphics remain clear and easy to read in all light conditions. Operation is made easier thanks to a centralised layout of switches, while the short lever joysticks further improve controllability and reduce operator effort.

The advanced Case hydraulic system allows up to 10 auxiliary hydraulic flow settings to be programmed into the machine's memory, making it possible to use up to 10 different attachments with no manual adjustment to hydraulic circuit necessary. This means that the operator can change from a breaker setting of flow and pressure, to a shear without leaving the seat.

OPERATOR'S CAB

The upgraded CXB cab has slim pillars and 60 % more glass, including a single piece window on the right hand side, promoting improved visibility all round the machine. Despite this, the cab is three times stronger than previously, thanks to the design of the structure. The main windscreen has a retractable sun visor and can be lifted into the roof space for a clear view of the digging area. Improvements in cab strength, combined with viscous liquid cab mounts, result in best in class low levels of noise and vibration. Longer seat slides, adjustable consoles, up to 60 mm increase in foot space, a fully reclining operator's seat and standard air conditioning with nine outlet vents ensure that the operator stays comfortable and productive throughout the working day. Operator comfort is further enhanced by a clock, a large storage area behind the driver's seat, bottle and can holders, a mobile phone holder and a cool box that uses the air conditioning system to regulate internal temperature.



MAINTENANCE



All engine and hydraulic filters are centralised and remote mounted within a large access panels, allowing ground level maintenance and reducing service time. Case excavators achieve the lowest score in SAE Maintenance score system tests, minimising downtime and reducing operating costs. The larger fuel tank has both a drain cock and a removable service plate, to allow for easy cleaning in the case of fuel contamination. A green engine oil drainer helps reduce environmental impact with no risk of spillage during service. The standard high flow electric refuelling pump is twice as fast as previous models, with an auto stop function to make refilling easier. Centralised greasing systems are available as an option on all Case excavators.

UNDERCARRIAGE



Case undercarriage design has always promised long component life and low operating costs. The CX350B has an outstanding undercarriage for maximum stability, with heat treated drive sprockets for extended operation. The track rollers have a revised profile for lower wear, and the O-ring design prevents the ingress of abrasive material, further extending longevity. Robust track guides and improved track links, with new M-shaped seals and increased pin hardness, further boost durability and reliability.

IMPROVED PIN AND BUSHING LIFE



EMS chrome plated pins with brass bushing

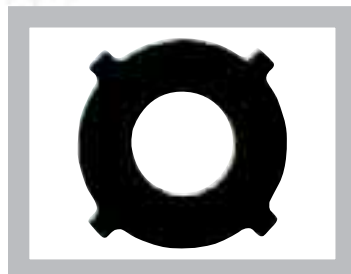

Anti-friction shims

Low maintenance Extended Maintenance Bushings (EMS) provide 1,000 hour greasing intervals, greatly reducing daily and weekly servicing for the operator. The bucket pins retain a 250 hour greasing interval. EMS bushings are now fitted as standard on all CXB excavators (previously only on machines above the CX330). Anti-friction shims in the boom foot and head reduce noise and cut free play, further increasing the well deserved Case reputation for durability and reliability, reducing ownership and operating costs for the customer.







SPECIFICATIONS

ENGINE

Latest generation engine, meeting European requirements for "Low exhaust emissions" Tier III in accordance with directive 97 / 68 / EC
 Make _____ ISUZU
 Type _____ AH-6HK1XYSS
 Common rail, turbo, intercooler, fuel cooler EGR (Exhaust Gas Recirculator) _____ Yes
 Direct injection _____ Electronically controlled
 Number of cylinders _____ 6
 Bore - Stroke _____ 115 x 125 mm
 Cubic capacity _____ 7790 cc
 Horsepower EEC80 / 1269 __ 202 kW / 275 hp @ 2200 rpm
 Maximum Torque _____ 1080 Nm @ 1500 rpm

HYDRAULIC SYSTEM

Max output _____ 2 x 290 l/min @ 1930rpm
 2 axial piston, variable flow pumps _____ Yes
 Attachment / Power Boost _____ 34.3 / 37.3 Mpa
 Upperstructure swing _____ 30.4 Mpa
 Travel _____ 34.3 Mpa
 Oil filtration _____ 6 micron
 Type of oil filter _____ Synthetic fiber Super fine High catch

SWING

Max upperstructure swing speed _____ 9.8 rpm
 Swing torque _____ 112 kN.m

TRAVEL

The travel circuit is equipped with axial piston, variable flow motors
 Max travel speed _____ 5.5 km/h
 Low travel speed _____ 3.5 km/h
 Speed change is controlled from the instrument panel
 Automatic downshifting _____ yes
 Gradeability _____ 70% (35°)
 Tractive force _____ 265.2 kN

ELECTRICAL SYSTEM

Circuit _____ 24V
 Batteries _____ 2 X 12V - 128A/h
 Circuit equipped with water-proof connectors _____ yes
 Alternator _____ 24V - 5.0kW

UNDERCARRIAGE

Upper rollers _____ 2
 Lower rollers _____ 8
 Number of track pads _____ 48
 Type of shoes _____ Triple grouser
 Track pad width Standard _____ 600 mm
 Track guard _____ Front and 1 central

CIRCUIT AND COMPONENT CAPACITIES

Fuel tank _____ 580 l
 Hydraulic reservoir _____ 350 l
 Hydraulic system _____ 175 l
 Travel reduction gear (per side) _____ 9.5 l
 Swing reduction gear _____ 7.9 l
 Engine oil (including filter change) _____ 38 l
 Engine cooling system _____ 30 l

BUCKETS

GENERAL PURPOSE

SAE capacity	l	740	940	1150	1360	1580	1800	2010
Width	mm	750	900	1050	1200	1350	1500	1650
Weight	kg	770	820	910	1000	1150	1230	1330

HEAVY DUTY

SAE capacity	l	740	940	1150	1360	1580	1800	2010
Width	mm	750	900	1050	1200	1350	1500	1650
Weight	kg	864	938	1096	1243	1350	1429	1537

EXTRA HEAVY DUTY

SAE capacity	l	1360
Width	mm	1200

QUARRY

SAE capacity	l	2010
Width	mm	1650
Weight	kg	1660

For other bucket sizes, please contact your CASE dealer



GENERAL DIMENSIONS

WITH 6.45 m STANDARD BOOM

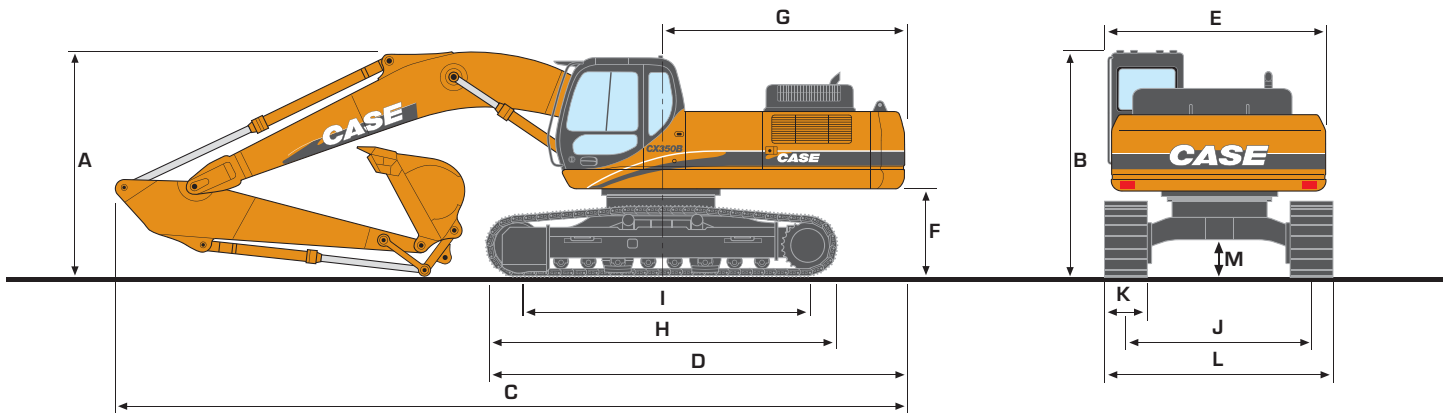

DIPPER LENGTH

		3.25 m	2.21 m	2.63 m	4.04** m
A Overall height (with attachment)	m	3.51	3.5	3.26	3.48
B Height (cab/handrail)	m	3.13	3.13	3.13	3.13
C Overall length (with attachment)	m	11.26	11.13	11.05	11.09
D Overall length (without attachment)	m	5.73	5.73	5.73	5.73
E Width of upperstructure	m	3.02	3.02	3.02	3.02
F Upperstructure ground clearance	m	1.21	1.21	1.21	1.21
G Swing radius (rear end)	m	3.42	3.42	3.42	3.42
H Track overall length	m	4.98	4.98	4.98	4.98
I Centre idler to centre sprocket	m	4.04	4.04	4.04	4.04
J Track gauge*	m	2.60	2.60	2.60	2.6
K Track shoe width standard	mm	600	600	600	600
L Track overall width	m	3.20	3.20	3.20	3.2
	- 600 mm shoes***				
	- 700 mm shoes****	3.40	3.40	3.40	3.4
	- 800 mm shoes****	3.60	3.60	3.60	3.6
	- 900 mm shoes****	3.80	3.80	3.80	3.8
N Ground clearance	m	0.48	0.48	0.48	0.48

* Standard gauge (2,39m for NLC)

** Only available on CX350B

*** 2.99 m NLC

**** Remove 0,21m to get track width of NLC configuration

WEIGHT AND GROUND PRESSURE

With 3,25 arm - 1,4 m³ bucket, operator, lubricant, coolant and full fuel tank operator and full fuel tank

	CX350B	
	WEIGHT (kg)	GROUND PRESSURE (MPa)
shoes 600 mm steel	34 200	0.064

With 3,25 arm - 1,4m³ HD bucket, operator, lubricant, coolant and full fuel tank operator and full fuel tank

	CX370B	
	WEIGHT (kg)	GROUND PRESSURE (MPa)
shoes 600 mm steel	36 200	0.068

CX370B

PERFORMANCE DATA

WITH 6.45 m STANDARD BOOM

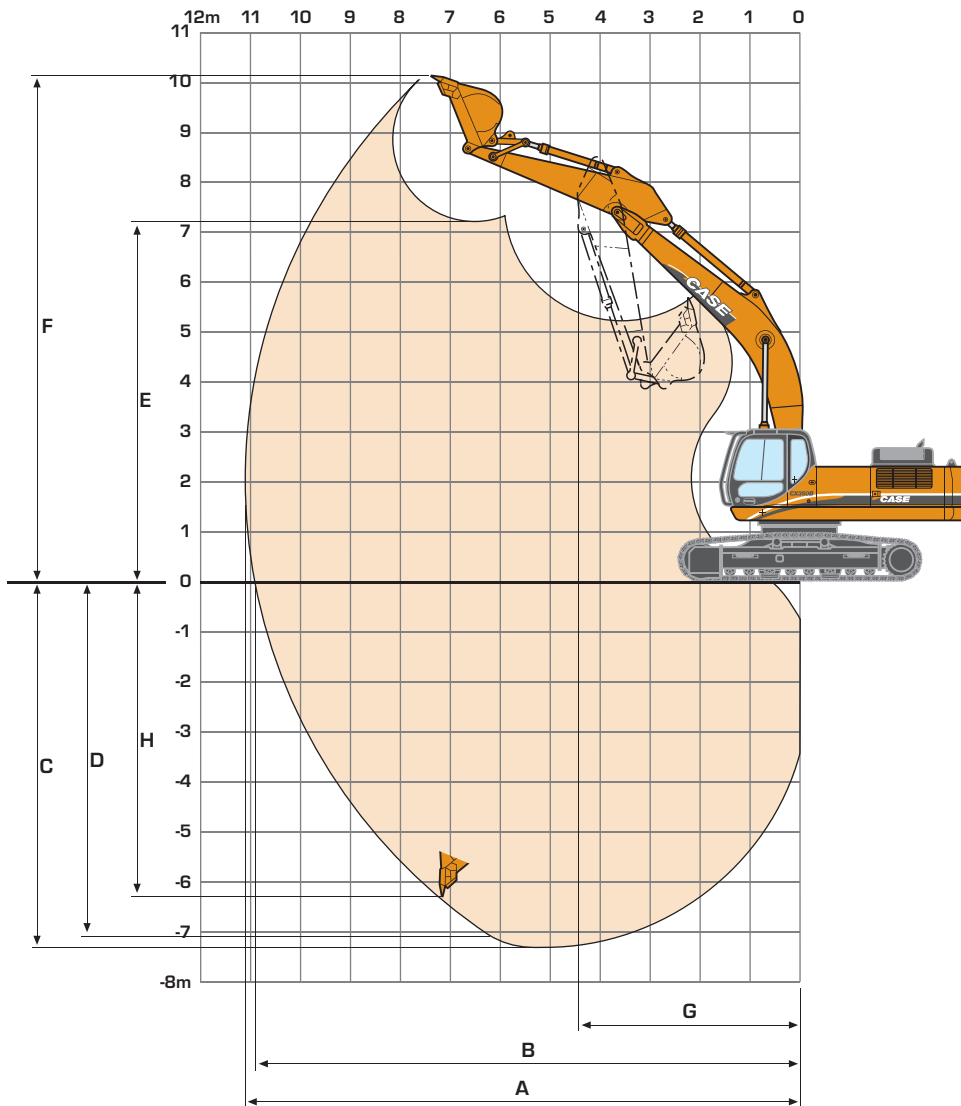

DIPPER LENGTH

			3.25 m	2.21 m	2.63 m	4.04 m
A	Maximum digging reach	mm	10.2	10.67	11.17	11.9
B	Maximum digging reach at ground level	mm	9.99	10.47	10.98	11.72
C	Maximum digging depth	mm	7.34	6.30	6.73	8.14
D	Digging depth - 2.44 m level bottom	mm	7.19	5.08	6.55	8.01
E	Max dump height	mm	6.77	7.14	7.23	7.54
F	Overall reach height	mm	9.85	10.32	10.37	10.67
G	Minimum swing radius - attachment	mm	3.42	3.42	3.42	3.42
H	Vertical straight wall dig depth	mm	6.35	6.10	5.97	7.15
	Digging force					
	- w/o Power Boost	kN	227	195	164	141
	- with Power Boost	kN	246	211	178	153
	Breakout force					
	- w/o Power Boost	kN	228.8	228.8	228.8	228.8
	- with Power Boost	kN	248.4	248.4	248.4	248.4

LIFTING CAPACITY CX350B

WITH 6.45 m STANDARD MONOBOOM

Values are expressed in kilos

Front 360°	REACH											
	3.0 m		4.5 m		6.0 m		7.5 m		9.0 m		At max reach	

LC - 2.21 m arm length, 600 mm shoes, bucket of 1.6 m³ - 1239 kg. Maximum reach 8.63 m

7.5 m												8777*	8508	6.33
6.0 m					9383*	9055	8607*	6094				8564*	5847	7.67
4.5 m			13555*	13432	10543*	8481	9056*	5853				7984	4907	8.27
3.0 m			16600*	11924	11933*	7824	9115	5533				7305	4417	8.58
1.5 m			18352*	11017	12494	7291	8791	5242				7079	4223	8.61
0 m			18438*	10745	12145	6989	8580	5052				7264	4296	8.38
-1.5 m	18703*	18703*	17487*	10773	12053	6909	8530	5007				7981	4701	7.85
-3.0 m	19964*	19964*	15532*	11007	11920*	7037						9694	5700	6.96
-4.5 m			11950*	11510								9752*	8367	5.54
-6.0 m														

LC - 2.63 m arm length, 600 mm shoes, bucket of 1.6 m³ - 1239 kg. Maximum reach 9.18 m

7.5 m												8021*	7424	6.86
6.0 m							8066*	6153				6596*	5070	8.28
4.5 m					9943*	8584	8603*	5883				6735*	4327	8.85
3.0 m			15681*	12250	11419*	7911	9133	5543	6724	4033		6553	3927	9.13
1.5 m			17885*	11186	12554	7334	8780	5225	6555	3882		6364	3764	9.17
0 m			18485*	10749	12136	6972	8530	5000				6504	3816	8.95
-1.5 m	15930*	15930*	17892*	10681	11976	6833	8427	4907				7053	4129	8.45
-3.0 m	21906*	21906*	16262*	10843	12048	6895	8518	4989				8301	4871	7.64
-4.5 m	17240*	17240*	13200*	11246	9849*	7202						9009*	6624	6.37
-6.0 m														

LC - 3.25 m arm length, 600 mm shoes, bucket of 1.4 m³ - 1169 kg. Maximum reach 9.67 m

7.5 m							6372*	6372*				6026*	6026*	7.62
6.0 m							7407*	6325				4537*	4537*	8.83
4.5 m					9138*	8845	8039*	6036	6562*	4304		4636*	3977	9.36
3.0 m	13761*	13761*	14412*	12841	10734*	8164	8881*	5677	6813	4122		4902*	3624	9.63
1.5 m	7198*	7198*	17144*	11619	12219*	7539	8893	5329	6608	3933		5371*	3470	9.66
0 m	10610*	10610*	18426*	10971	12282	7102	8595	5061	6448	3786		5973	3496	9.45
-1.5 m	15484*	15484*	18387*	10751	12028	6881	8428	4911				6397	3734	8.99
-3.0 m	21488*	21488*	17249*	10798	11999	6857	8422	4905				7345	4298	8.22
-4.5 m	20317*	20317*	14834*	11073	11138*	7033						8928*	5547	7.6
-6.0 m			10201*	10201*								8572*	8572*	5.24

LC - 4.04 m arm length, 600 mm shoes, bucket of 1.15 m³ - 1046 kg. Maximum reach 10.43 m

7.5 m												4513*	4513*	8.57
6.0 m									5444*	4545		3460*	3460*	9.65
4.5 m							7152*	6176	6683*	4378		3510*	3406	10.1
3.0 m			12401*	12401*	9573*	8401	8076*	5773	6855	4152		3677*	3112	10.4
1.5 m	12183*	12183*	15558*	11976	11256*	7672	8943	5364	6599	3917		3977*	2971	10.4
0 m	11487*	11487*	17603*	11021	12303	7107	8506	5024	6381	3717		4462*	2971	10.2
-1.5 m	14351*	14351*	18274*	10576	11912	6668	8315	4800	6241	3588		5240*	3129	9.79
-3.0 m	18657*	18657*	17793*	10475	11766	6642	8217	4712	6222	3570		6122	3513	9.01
-4.5 m	23128*	22228	16143*	10630	11847	6712	8302	4788				7448	4313	8.07
-6.0 m	17821*	17821*	12857*	11055	9412*	7025						8256*	6193	6.54

Tipping capacity 75.0 %.

Asterisk (*) = Hydraulic capacity 87%

LIFTING CAPACITY CX350B

WITH 6.45 m STANDARD MONOBOOM

Values are expressed in kilos

Front 360°	REACH											
	3.0 m		4.5 m		6.0 m		7.5 m		9.0 m		At max reach	

NLC - 2.21 m arm length, 600 mm shoes, bucket of 1.6 m³ - 1239 kg. Maximum reach 8.63 m

7.5 m												8777*	7812	6.33
6.0 m					9383*	8300	8607*	5569				8564*	5339	7.67
4.5 m			13555*	12184	10543*	7737	9056*	5332				7958	4458	8.27
3.0 m			16600*	10723	11933*	7095	9085	5017				7280	3993	8.58
1.5 m			18352*	9845	12453	6573	8761	4731				7054	3804	8.61
0 m			18438*	9581	12104	6277	8550	4544				7238	3861	8.38
-1.5 m	18703*	18703*	17487*	9609	12012	6199	8500	4499				7953	4226	7.85
-3.0 m	19964*	19964*	15532*	9835	11920*	6324						9661	5132	6.96
-4.5 m			11950*	10322								9752*	7545	5.54

NLC - 2.63 m arm length, 600 mm shoes, bucket of 1.6 m³ - 1239 kg. Maximum reach 9.18 m

7.5 m												8021*	6814	6.86
6.0 m							8066*	5626				6596*	4617	8.28
4.5 m					9943*	7837	8603*	5361				6735*	3919	8.85
3.0 m			15681*	11037	11419*	7178	9103	5026	6700	3641		6530	3538	9.13
1.5 m			17885*	10006	12512	6613	8750	4713	6532	3488		6341	3379	9.17
0 m			18485*	9583	12095	6259	8500	4492				6480	3419	8.95
-1.5 m	15930*	15930*	17892*	9517	11935	6123	8396	4400				7027	3701	8.45
-3.0 m	21906*	19836	16262*	9674	12006	6184	8488	4481				8272	4375	7.64
-4.5 m	17240*	17240*	13200*	10065	9849*	6485						9009*	5969	6.37

NLC - 3.25 m arm length, 600 mm shoes, bucket of 1.4 m³ - 1169 kg. Maximum reach 9.67 m

7.5 m							6372*	5934				6026*	5756	7.62
6.0 m							7407*	5795				4537*	4191	8.83
4.5 m					9138*	8093	8039*	5511	6562*	3904		4636*	3598	9.36
3.0 m	13761*	13761*	14412*	16611	10704*	7427	8881*	5158	6790	3724		4902*	3203	9.63
1.5 m	7198*	7198*	17144*	10427	12219*	6814	8863	4816	6584	3538		5371*	3112	9.66
0 m	10610*	10610*	18426*	9799	12241	6387	8564	4552	6425	3393		5951	3128	9.45
-1.5 m	15484*	15484*	18387*	9586	11986	6171	8398	4405				6374	3341	8.99
-3.0 m	21488*	19635	17249*	9632	11958	6147	8391	4399				7318	3853	8.22
-4.5 m	20317*	20200	14834*	9898	11138*	6320						8928*	4991	7.06
-6.0 m			10201*	10201*								8572*	8287	5.24

NLC - 4.04 m arm length, 600 mm shoes, bucket of 1.15 m³ - 1046 kg. Maximum reach 10.43 m

7.5 m												4513*	4513*	8.57
6.0 m									5444*	4140		3460*	3460*	9.65
4.5 m							7152*	5647	6683	3975		3510*	3066	10.1
3.0 m			12401*	12197	9573*	7655	8076*	5250	6837	3752		3677*	2784	10.4
1.5 m	12183*	12183*	15588*	10767	11256*	6941	8920	4848	6581	3520		3977*	2646	10.4
0 m	11487*	11487*	17603*	9843	12272	6389	8542	4513	6363	3322		4462*	2969	10.2
-1.5 m	14351*	14351*	18274*	9412	11880	6057	8292	4292	6223	3195		5240*	2778	9.79
-3.0 m	18657*	18657*	17793*	9314	11734	5933	8194	4206	6204	3178		6105	3127	9.01
-4.5 m	23128*	19345	16143*	9463	11815	6002	8279	4281				7427	3855	8.07
-6.0 m	17821*	17821*	12857*	9875	9412*	6308						8256*	5566	6.54

Tipping capacity 75.0 %.
Asterisk (*) = Hydraulic capacity 87%



LIFTING CAPACITY CX370B

WITH 6.45 m STANDARD MONOBOOM

Values are expressed in kilos

Front 360°	REACH											
	3.0 m		4.5 m		6.0 m		7.5 m		9.0 m		At max reach	

LC - 2.21 m arm length, 600 mm shoes, bucket of 1.6 m³ - 1573 kg. Maximum reach 8.63 m

7.5 m												8431 *	8431 *	6.33
6.0 m					9032 *	9032 *	8239 *	6400				8194 *	6134	7.67
4.5 m			13161 *	13161 *	10164 *	8977	8677 *	6147				8229 *	5128	8.27
3.0 m			16127 *	12705	11518 *	8281	9323 *	5809				7638	4604	8.58
1.5 m			17826 *	11734	12601 *	7714	9232	5500				7397	4398	8.61
0 m			17894 *	11440	12819	7390	9007	5298				7596	4479	8.38
-1.5 m	18437 *	18437 *	16944 *	11469	12720	7304	8951	5248				8363	4917	7.85
-3.0 m	19317 *	19317 *	15000 *	11717	11453 *	7437						9503 *	5993	6.96
-4.5 m			11443 *	11443 *								9289 *	8862	5.54

LC - 2.63 m arm length, 600 mm shoes, bucket of 1.6 m³ - 1573 kg. Maximum reach 9.18 m

7.5 m												7595 *	7595 *	6.86
6.0 m							7621 *	6399				6285 *	5233	8.28
4.5 m					9475 *	9010	8138 *	6109				6422 *	4435	8.85
3.0 m			15093 *	12933	10901 *	8282	8852 *	5741	6946	4123		6764	4004	9.13
1.5 m			17222 *	11777	12128 *	7656	9135	5397	6764	3956		6560	3828	9.17
0 m			17792 *	11302	12699	7264	8864	5153				6708	3884	8.95
-1.5 m	15621 *	15621 *	17194 *	11229	12525	7113	8752	5052				7291	4219	8.45
-3.0 m	21060 *	21060 *	15576 *	11405	11729 *	7181	8806 *	5141				8542 *	5014	7.64
-4.5 m	16437 *	16437 *	12542 *	11844	9267 *	7514						8454 *	6894	6.37

LC - 3.25 m arm length, 600 mm shoes, bucket of 1.4 m³ - 1498 kg. Maximum reach 9.67 m

7.5 m							6047 *	6047 *				5700 *	5700 *	7.62
6.0 m							6950 *	6568				4212 *	4212 *	8.83
4.5 m					8664 *	8664 *	7558 *	6254	6238 *	4388		4311 *	4035	9.36
3.0 m	13429 *	13429 *	13825 *	13542	10202 *	8532	8369	5862	7021	4191		4579 *	3655	9.63
1.5 m	6871 *	6871 *	16456 *	12197	11631 *	7845	9165 *	5482	6798	3985		5048 *	3488	9.66
0 m	10283 *	10283 *	17684 *	11483	12564 *	7365	8905	5188	6623	3825		5814 *	3515	9.45
-1.5 m	15157 *	15157 *	17629 *	11243	12541	7124	8724	5025				6568	3769	8.99
-3.0 m	21159 *	21159 *	16498 *	11299	12230 *	7099	8717	5019				7576	4372	8.22
-4.5 m	19415 *	19415 *	14109 *	11606	10510 *	7295						8350 *	5711	7.06
-6.0 m			9528 *	9528 *								7949 *	7949 *	5.24

LIFTING CAPACITY CX370B

WITH 6.45 m STANDARD MONOBOOM

Values are expressed in kilos

Front 360°	REACH						m
	3.0 m	4.5 m	6.0 m	7.5 m	9.0 m	At max reach	

NLC - 2.21 m arm length, 600 mm shoes, bucket of 1.6 m³ - 1573 kg. Maximum reach 8.63 m

7.5 m											8431 *	8255	6.33
6.0 m					90321 *	8789	8232	5849			8194 *	5601	7.67
4.5 m			13161 *	12994	10164 *	8195	8677 *	5600			8229 *	4657	8.27
3.0 m			16127 *	11440	11518 *	7514	9323 *	5268			7615	4160	8.58
1.5 m			17826 *	10498	12601 *	6959	9205	4964			7375	3959	8.61
0 m			17894 *	10214	12782	6642	8980	4765			7573	4023	8.38
-1.5 m	18437 *	18437 *	16944 *	10242	12682	6558	8924	4715			8338	4418	7.85
-3.0 m	19317 *	19317 *	15000 *	10482	11453 *	6688					9503 *	5396	6.96
-4.5 m			11443 *	10998							9289 *	7997	5.54

NLC - 2.63 m arm length, 600 mm shoes, bucket of 1.6 m³ - 1573 kg. Maximum reach 9.18 m

7.5 m											7595 *	7123	6.86
6.0 m							7621 *	5845			6285 *	4758	8.28
4.5 m					9465 *	8224	838 *	5560			6422 *	4007	8.85
3.0 m			15093 *	11655	10901 *	7511	8852 *	5198	6925	3707	6743	3597	9.13
1.5 m			17222 *	10535	12128 *	6899	9108	4859	6743	3542	6540	3425	9.17
0 m			17792 *	10076	12662	6515	8837	4619			6686	3468	8.95
-1.5 m	15621 *	15621 *	17194 *	10004	12488	6368	8725	4521			7268	3770	8.45
-3.0 m	21060 *	21060 *	15576 *	10175	11729 *	6434	8806 *	4608			8542 *	4494	7.64
-4.5 m	16437 *	16437 *	12542 *	10600	9277 *	6759					8454 *	6207	6.37

NLC - 3.25 m arm length, 600 mm shoes, bucket of 1.4 m³ - 1498 kg. Maximum reach 9.67 m

7.5 m							6047 *	6047 *			5700 *	5700 *	7.62
6.0 m							6950 *	6011			4212 *	4212 *	8.83
4.5 m					8664 *	8485	7558 *	5702			6238 *	3969	9.36
3.0 m	13429 *	13429 *	13825 *	12245	10202 *	7755	8369 *	5317	7000	3774	4579 *	3276	9.63
1.5 m	6871 *	6871 *	16456 *	10941	11631 *	7084	9165 *	4943	6776	3571	5048 *	3113	9.66
0 m	10283 *	10283 *	17684 *	10250	12564 *	6614	8878	4654	6602	3413	5814 *	3129	9.45
-1.5 m	15157 *	15157 *	17629 *	10018	12504	6378	8697	4492			6547	3356	8.99
-3.0 m	21159 *	20751	16498 *	10072	12230 *	6353	8690	4488			7552	3906	8.22
-4.5 m	19415 *	19415 *	14109 *	10369	10510 *	6545					8350 *	5127	7.06
-6.0 m			9528 *	9528 *							7949 *	7949 *	5.24





CX350B CX370B

STANDARD EQUIPMENT & OPTIONS

STANDARD EQUIPMENT

Engine control

- Common rail engine Tier III European Standards
- Electronic control of the injection system
- Automatic engine pre-heating
- Automatic/manual engine return to idle
- Exhaust Gas Recirculator
- Emergency stop
- Electrical refuel pump with automatic stop
- Fuel filter with water separator

Hydraulic control

- Auto / Heavy / Super Power working modes
- Pump torque variable control
- Automatic Power boost control
- Swing brake control
- High performance "Super Fine" synthetic fiber hydraulic filter (high contamination catch)
- Hydraulic safety valves on boom and dipper
- 2 travel speeds with auto down shifting

Operator environment

- High visibility cab with safety glass
- Adjustable et retractable armrest console with position memory
- Safety lever
- Self adjusting Air conditioning and heating system
- Cup holder
- High visibility side monitor display with automatic brightness
- Messages (function, temperature, safety, ...) on the display
- Integrated diagnostic system
- Working modes (Auto/Heavy/Super Power) combined with engine throttle
- Anti-theft device
- Hourmeter
- Selectable auxiliary hydraulic flow pre-settings
- RH front console with clock and cell phone holder
- High capacity shock absorbers on cab with 4 points fluid mountings
- Rain deflector
- Windscreen with lockable opening
- Windscreen washer and wiper
- Removable lower front windscreen with storage location in cab
- Glass cab roof window and slidding sun shade
- ISO control pattern low effort & short joysticks
- Adjustable sun visor

- Washable cab floor mat
- Rear view mirror and safety mirrors
- Storage compartments
- Integrated cool box
- 12V and 24V DC accessory sockets
- Hammer / Shear change selected from the cab
- Fore & aft adjustment of the whole seat & console

Electrical system

- Water proof connectors
- Double horn
- 2 working light on the cab
- Working light on the fuel tank
- Working light on the boom

Equipment

- EMS (Extended Maintenance System) pins and bushings as Standard (1000 hours lubrication interval for all, except buckets pins at 250 hours)
- Low friction resin side shims on boom and dipper
- Sealed and lubricated tracks
- Track guides (1 guide & front)
- Large tool box
- Pre-disposal for the optional cab protection

Operator seat

- Fully adjustable low frequency mechanical suspension seat including double acting hydraulic damper
- Weight adjustment
- Height / fore & aft adjustment
- Adjustable head rest
- Adjustable seat back angle with Fully flat seat reclining
- Adjustable arm rest
- Safety belt

OPTIONS

- Bucket/clamshell hydraulic circuit
- Hammer hydraulic circuit
- Hammer/shear hydraulic circuit
- Additional track guides up to 900 mm width
- Track width (500mm - 600mm - 700mm depending on the version)
- Windscreen protection
- Cab protection
- GPS (Global Positioning System) by satellite
- Centralized greasing system automatically actuated by an electrical grease pump

Standard and optional equipment shown can vary by country.

Worldwide Case Construction Equipment Contact Information

EUROPE/AFRICA/MIDDLE EAST:
Centre D'affaires EGB
5, Avenue Georges Bataille - BP 40401
60671 Le Plessis-Belleville - FRANCE

NORTH AMERICA/MEXICO:
700 State Street
Racine, WI 53404 U.S.A.

LATIN AMERICA:
Av. General David Sarnoff 2237
32210 - 900 Contagem - MG
Belo Horizonte BRAZIL

ASIA PACIFIC:
Unit 1 - 1 Foundation Place - Prospect
New South Wales - 2148 AUSTRALIA

CHINA:
No. 29, Industrial Premises, No. 376,
De Bao Road, Waigaoqiao Ftz, Pudong,
SHANGHAI, 200131, P.R.C.



The call is free from a land line. Check in advance with your Mobile Operator if you will be charged.

NOTE: Standard and optional fittings can vary according to the demands and specific regulations of each country. The illustrations may include optional rather than standard fittings - consult your Case dealer. Furthermore, CNH reserves the right to modify machine specifications without incurring any obligation relating to such changes.



Conforms to directive 98/37/CE

CASE Construction Equipment

CNH UK Ltd
Unit 4,
Hayfield Lane Business Park,
Field Lane, Auckland,
Doncaster,
DN9 3FL
Tel. 00800-2273-7373
Fax +44 1302 802829

www.casece.com

CASE
CONSTRUCTION