



City Crane ATC 20

ATC 20

CARRO



TRAZIONE/STERZO

4x4x4

STABILIZZATORI

Idraulici con comandi indipendenti posti in cabina. Escursione parziale con possibilità di bloccaggio in 3 posizioni.

PONTI

Anteriore e posteriore traenti e sterzanti con differenziale e riduzioni planetarie fissati al telaio con barre di reazione. Bloccaggio differenziale su entrambi i ponti.

SOSPENSIONI

Idropneumatiche indipendenti, bloccabili individualmente; livellamento automatico per marcia su strada

STERZO

Ad azionamento meccanico servoassistito.
4 possibilità di sterzata.

FRENI

A doppio circuito indipendente a comando pneumatico. ABS, freno di parcheggio

PNEUMATICI

365/85 R20, montati in singolo, adatti per un impiego su strada e fuoristrada.

TORRETTA

BRACCIO

Telescopico a 6 sezioni da 5,6 m a 23,8 m. Sfilamento completamente idraulico con sincronizzazione filo e rientro degli elementi a controllo elettronico.

SOLLEVAMENTO BRACCIO

Da -6° a +80°.

ROTAZIONE

Continua su 360°.

ARGANO

Posto direttamente su lbraccio, azionato da motore a pistoni. Freno a dischi multipli e valvola di controbilanciamento.

MOTORE

IVECO NEF Common Rail EURO 3, 6 cilindri diesel, raffreddamento ad acqua. Potenza 176 kW (240 CV) a 2500 giri/min.

TRASMISSIONE

Idrostatica a circuito chiuso. Comando completamente elettronico della trazione.

CABINA

De luxe monoposto, in acciaio, completa di tutti i comandi gru e trasferimento su strada.

CONTROLLO ELETTRONICO

Il motore diesel, la trazione, i movimenti della gru e il limitatore di carico sono controllati elettronicamente (LOCATRONIC).

IMPIANTO ELETTRICO

A 24 volt. Impianto di illuminazione secondo le norme europee.

CHASSIS



DRIVING/STEERING

4x4x4

OUTRIGGERS

Telescopic, independent type, hydraulically operated from the cab. Extension lockable in 3 positions.

AXLES

Front and rear driving/steering axles with differential lock and planetary reduction constrained to the frame by reaction bars. Differential lockout on both axles.

SUSPENSIONS

Adjustable, hydropneumatically operated independent suspensions; automatic levelling for road travel.

STEERING

Mechanical hydraulically assisted steering system. Four steering modes available.

BRAKES

Air controlled, dual independent braking system; ABS, parking brake.

TYRES

365/85 R20 single mounted front and rear, suitable for on- and off-the-road operation.

SUPERSTRUCTURE

BOOM

Six section fully powered telescopic boom from 5,6 to 23,8 m. Electronically controlled synchronization of boom telescope and retraction.

BOOM ELEVATION

From -6° through +80°.

SLEW

360° continuous rotation.

HOIST

Boom mounted, operated by piston motor; multi-disc brake and counterbalance valve.

ENGINE

IVECO NEF Common Rail EURO 3, water cooled 6 cylinder diesel, 176 kW (240 HP) at 2500 rpm.

TRANSMISSION

Hydrostatic with continuous speed regulation. Fully electronic drive control.

CABIN

De luxe type, one man design with all crane and travel controls.

ELECTRONIC SYSTEM

The diesel engine, the crane drive, crane motions and the safe load indicator are electronically controlled by the LOCATRONIC system.

ELECTRICAL EQUIPMENT

24 Volt complying with EC road traffic regulation.



▲ Montante industriale 1,15m
Runner 1,15m
Schwerlastspitze 1,15 m
Flèche de montage 1,15 m

▲ Falcone telescopico 8,0 m
Foldable fly jib 8,0 m
Faltbare Klappspitze 8,0 m
Extension télescopique répliable 8,0 m

▲ Forche, 4.000kg capacità
Forks, 4.000kg capacity
Gabeln, 4.000kg Tragkraft
Fourches, 4.000kg force de levage



▲ Cesta rotante pieghevole 250 daN, 33m altezza di lavoro
Foldable rotating platform 250 daN, 33m working height
Drehbares faltbares Arbeitskorb 250 daN, 33m Arbeitshöhe
Nacelle orientable répliable 250 daN, 33m hauteur de travail

▲ Cesta rotante sul braccio idraulico telescopico 250 daN
Rotating platform on hydraulic extension 250 daN
Drehbares Arbeitskorb auf hydraulische Gelenkspitze 250 daN
Nacelle orientable sur flèche télescopique hydraulique 250 daN

ACCESSORI OPZIONALI	OPTIONAL EQUIPMENT	ZUSATZAUSRÜSTUNG	OPTIONS ET EQUIPMENTS
Radiocomando	Remote control	Fernbedienung	Télécommande
Sistema centralizzato di lubrificazione del carro	Automatic centralised lubrication for carrier	Automatische Zentralschmieranlage fuer den Unterwagen	Système automatique de graissage centralisé pour le chassis
Catalizzatore	Catalytic muffler	Katalysator	Pot catalytique
Ruota di scorta	Spare wheel	Reserverad	Roue de secours
Gancio di rimorchio	Tow hook	Anhaengerkupplung	Crochet d'attelage
Climatizzatore automatico	Automatic climate control incorporating air-conditioning	Automatische Klimaanlage	Climatiseur automatique en cabine

ATC 20



◀ Locatronic system



ATC 20

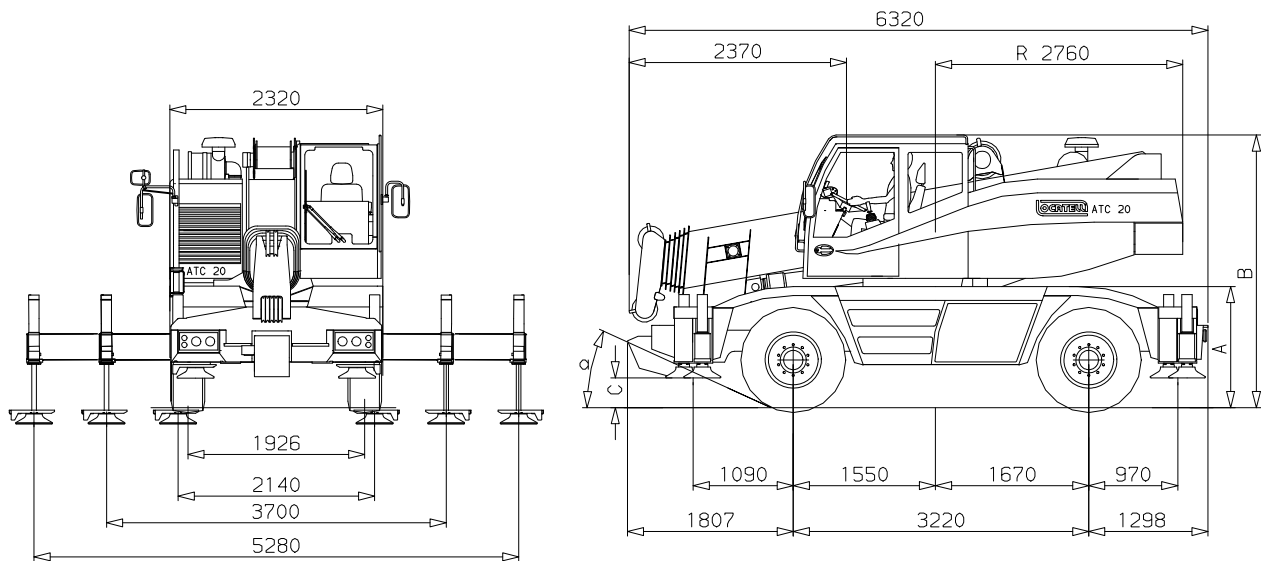

DIMENSIONI / DIMENSIONS / ABMESSUNGEN / DIMENSIONS

Pneumatici Type of tyres Pneus Bereifung	Assetto Assetto Level Niveau	A (mm)	B (mm)	C (mm)	a (°)
365/85 R 20	Stradale Road Route Strasse	1325	2975	325	24,5°
365/85 R 20	Ribassata Lowered Abaissé Abgelassen	1240	2890	240	19,5°

DATI TECNICI	TECHNICAL DATA	TECHNISCHE DATEN	DONNEES TECHNIQUES	
DATI GENERALI	GENERAL DATA	ALLGEMEINE DATEN	CARACTÉRISTIQUES GÉNÉRALES	
Pendenza superabile (pratica)	Max negotiable gradient (unladen)	Steigfähigkeit (praktisch)	Pente franchissable pratique	55%
Peso in ordine di marcia	Approx. weight in travel order	Gewicht in Fahrstellung	Poids de la machine de base	
• Totale	• Total	• Gesamt	• Total	Kg 18.000
• su asse anteriore	• On front axle	• Vorderachse	• Sur essieu AV	Kg 7.500
• su asse posteriore	• On rear axle	• Hinterachse	• Sur essieu AR	Kg 10.500
Raggio di sterzata	Turning radius	Wenderadius	Rayons de braquage	
• 2 ruote sterzanti	• 2 wheel steer	• Zweiradlenkung	• 1 essieu directeur	m 8,380
• 4 ruote sterzanti	• 4 wheel steer	• Vierradlenkung	• 2 essieux directeurs	m 5,580
PRESTAZIONI	PERFORMANCES	LEISTUNGEN	PERFORMANCES	
Tiro max argano	Hoist max pull	Hubwerk-Strangzug	Treuil effort maxi	24 kN
Velocità argano	Hoisting speed	Hubwerkgeschwindigkeit	Vitesse treuil de levage	0-115 m/min
Velocità di rotazione	Slewing speed	Drehgeschwindigkeit	Vitesse d'orientation	2,3 rpm
Velocità sollevamento braccio	Boom elevation speed	Auslegerhub	Relevage de flèche complet	45 sec
Velocità di sfilo	Boom telescoping speed	Teleskopiergeschwindigkeit	Télescopage complet	60 sec
Velocità su strada	Travelling speed on road	Fahrgeschwindigkeit	Vitesse sur route	71 Km/h

Dati e caratteristiche possono variare senza l'obbligo di preavviso.

In accordance with our policy of constant improvement we reserve the right to amend this specification at any time without notice.

Wir behalten uns vor, die technischen Daten im Zuge der Weiterentwicklung zu ändern.

Suivant notre politique d'amélioration continue, nous nous reservons le droit de modifier sans préavis certaines des caractéristiques indiquées dans cette notice.

LOCATELLI
AUTOGRU
High Quality Since 1954



Locatelli S.p.A.

Sede Amministrativa e Produttiva - Via Lombardia, 32 - 24030 Mapello (Bergamo) - Italy - Tel. +39 035 4945066 - Fax +39 035 4945549

Sedi Commerciali - Via dell'Industria 2 bis - 30031 Dolo (Venezia) - Italy // Via Lombardia, 32 - 24030 Mapello (Bergamo) - Italy

www.locatell crane.com - Email: info@locatell crane.com