

ELECTRIC RIDERS

Tri-Wheel Multi-Tire Lift Trucks Electric 48 Volt

TMX13	1250 kg
TMX15	1500 kg
TMX15s	1500 kg
TMX18	1815 kg
TMX20x	2000 kg

TMX13/15/15s/ 18/20x

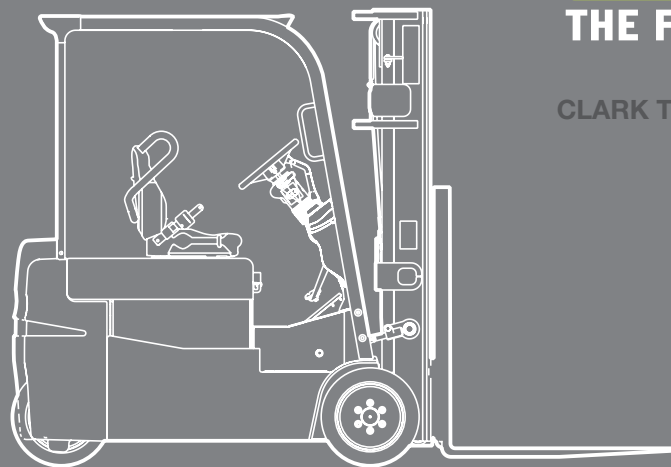

CLARK THE FORKLIFT

Europe

North America

South Korea

www.clarkmheu.com

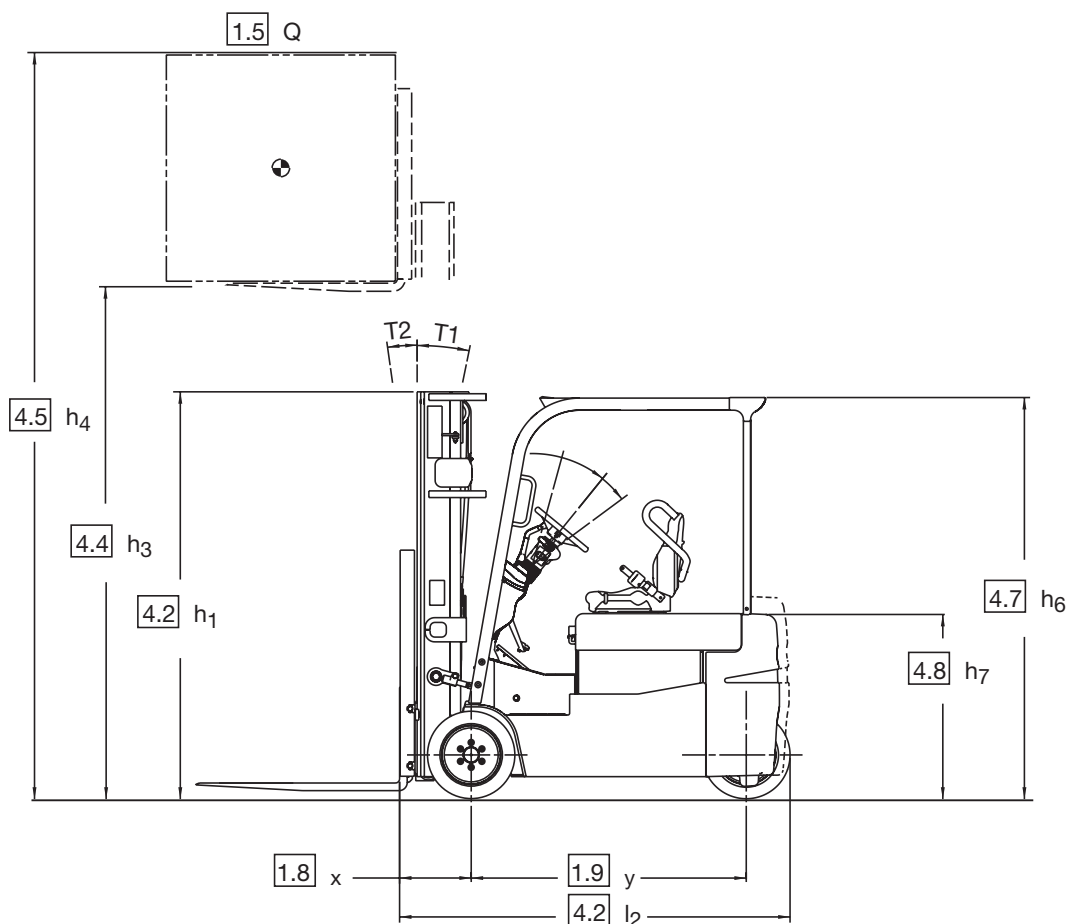

TMX13/15/15s/18/20x

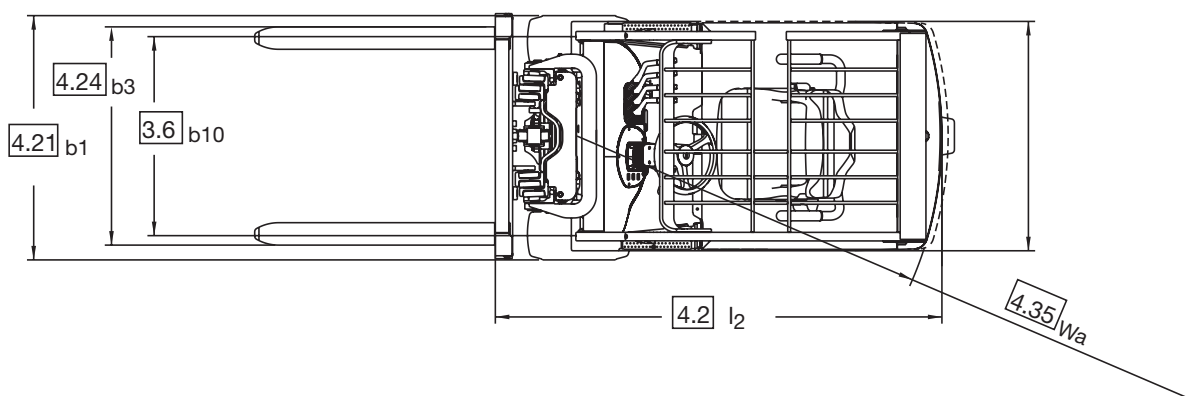

$$A_{st} = W_a + R + a$$

$a = 200$ mm (safety distance)

For corresponding data see
Specification Chart.

Truck Capacities

Capacity at different load centres

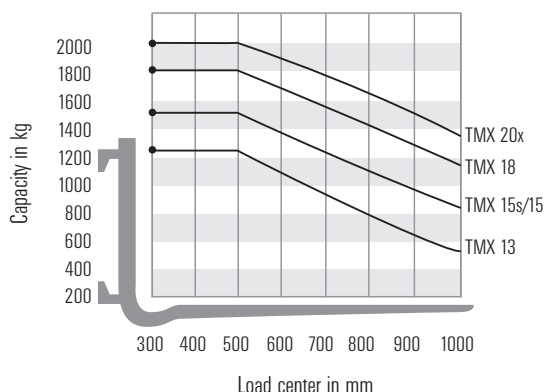

Note:

The listed capacities are valid only for the standard upright in vertical position with standard fork carriage and standard forks, up to max. lifting height of 3088 mm. The centre of gravity of the load may be displaced by max. 100 mm against the longitudinal centre plane of the truck. Load centre is determined from top and front face of the forks. The values are based on a 1000 mm cube load configuration with the centre of gravity at the true centre of the cube. With upright tilted forward lower capacity values are valid. Attachments, longer forks, exceptional load dimensions and higher lifting heights can reduce the capacity. Please talk to your CLARK dealer if you require further information.

Upright table

Capacity at different load centres

Upright table metrics in mm

CLARK Ref.	max. fork height h3	overall height lowered h1	free lift h2h5*
------------	---------------------	---------------------------	-----------------

Standard TMX 13/15s/15/18/20x

(2 Stage Mast, standard free lift)

V	2540	1842	109
V	2794	1969	109
V	3073	2108	109
V	3277	2210	109
V	3632	2388	109

* without LBR

Upright table metrics in mm

CLARK Ref.	max. fork height h3	overall height lowered h1	free lift h2h5*
------------	---------------------	---------------------------	-----------------

Triple TMX 13/15s/15/18/20x

(3 Stage Mast, full free lift)

M	3971	1840	1219
M	4346	1965	1355
M	4781	2110	1500
M	5184	2260	1650
M	5565	2420	1803
M	6017	2609	2004

* without LBR

Upright table metrics in mm

CLARK Ref.	max. fork height h3	overall height lowered h1	free lift h2h5*
------------	---------------------	---------------------------	-----------------

HiLo TMX 13/15s/15/18/20x

(2 Stage Mast, full free lift)

H	2921	1969	1346
H	3200	2108	1500
H	3810	2425	1803

* without LBR

Upright table metrics in mm

CLARK Ref.	max. fork height h3	overall height lowered h1	free lift h2h5*
------------	---------------------	---------------------------	-----------------

Quad TMX 13/15s/15/18/20x

(4 Stage Mast, full free lift)

Q	5652	1994	1346
Q	6109	2108	1448
Q	6566	2261	1600
Q	6871	2375	1778

* without LBR

ELECTRIC RIDERS

All values shown are for standard lift truck with standard equipment. If the truck is supplied with options, values may change. All values given may vary +5% and -10% due to the motor and system tolerances and represent nominal values obtained under typical operating conditions. Specifications for Non-emission limited truck.

SPECIFICATIONS

1.1 Manufacturer		CLARK	CLARK	CLARK	
Characteristics	1.2 Model	TMX13	TMX15s	TMX15	
	1.3 Drive	Battery	Battery	Battery	
	1.4 Operation	Seat	Seat	Seat	
	1.5 Load capacity	Q(Kg)	1250	1500	1500
	1.6 Load center	c (mm)	500	500	500
	1.8 Load center distance	x (mm)	366	366	366
	1.9 Wheelbase	y (mm)	1168	1168	1340
Weight	2.1 Service weight	kg	3223	3483	3369
	2.2 Axle loading with load front/rear 7)	kg	4043/439	4337/646	4169/700
	2.3 Axle loading without load front/rear 7)	kg	1844/1379	1834/1649	1812/1557
Tires, Chassis	3.1 Tire type 3)		SuperElastic	SuperElastic	SuperElastic
	3.2 Tire size front		18/7/12 12PR	18/7/12 12PR	18/7/12 12PR
	3.3 Tire size rear		15/4.5/8	15/4.5/8	15/4.5/8
	3.5 Number of tires front/rear		2x/1	2x/1	2x/1
	3.6 Track front	b10 (mm)	861	861	861
	3.7 Track rear	b11 (mm)	-	-	-
	Dimensions	4.1 Upright tilt back/forward T2/ T1	deg	6/8	6/8
4.2 Height, upright lowered		h1 (mm)	2108	2108	2108
4.3 Free lift		h2 (mm)	110	110	110
4.4 Lift height 1)		h3 (mm)	3088	3088	3088
4.5 Height, upright extended without LBR 2)		h4 (mm)	4307	4307	4307
4.7 Height over OHG		h6 (mm)	2108	2108	2108
4.8 Height to operator's seat		h7 (mm)	1100	1100	1100
4.12 Height, drawbar coupling		h10 (mm)	-	-	-
4.19 Overall length		l1 (mm)	2832	2832	3000
4.20 Overall length to fork face		l2 (mm)	1765	1765	1933
4.21 Overall width		b1 (mm)	1022	1022	1022
4.22 Std. fork size		s,e,1 (mm)	40-100-1067	40-100-1067	40-100-1067
4.23 Carriage DIN 15173, class			ISO 2A	ISO 2A	ISO 2A
4.24 Carriage width		b3 (mm)	940	940	940
4.31 Ground clearance min. with load		m1 (mm)	83	83	83
4.32 Ground clearance at center of wheelbase		m2 (mm)	104	104	104
4.33 Right angle stack aisle		(mm)	-	-	-
4.34 Process operation with palette 800x1200 (l6xb12)	Ast (mm)	-	-	-	
4.35 Turning radius	Wa (mm)	1356	1356	1519	
4.36 Inner center clearance	b13 (mm)	-	-	-	
Performance	5.1 Travel speed with/ without load	km/ h	15/15	15/15	15/15
	5.2 Lift speed with/ without load	m/ s	0,43/0,60	0,42/0,61	0,42/0,61
	5.3 Lower speed with/ without load	m/ s	0,45/0,41	0,45/0,41	0,45/0,41
	5.5 Traction with/ without load	N	-	-	-
	5.6 Max. traction with/ without load	N	-	-	-
	5.7 Gradeability	%	-	-	-
	5.8 Max. gradeability with/ without load 6)	%	-	-	-
	5.9 Acceleration time with/ without load 5)	S	-	-	-
	5.10 Service brake		Disk	Disk	Disk
	Drive Line	6.1 Drive motor power (S2 - 5 min.)	KW	5,2x2	5,2x2
6.2 Hydr. Motor power(S3 - 15%)		KW	15,2	15,2	15,2
6.3 Battery DIN 43531/35/36 A,B,C , no.			-	-	-
6.4 Battery voltage and capacity		V/Ah	48/400	48/775	48/775
6.5 Battery weight		kg	749	749	749
6.6 Max. capacity (6hr, rate) 4)		kWh	27	27	43
8.1 Drive motor control			AV Inverter	AV Inverter	AV Inverter
8.2 Pressure accessory equipment		bar	-	-	-
8.3 Amount of oil, accessory equipment		l/min	-	-	-
8.4 Sound level		dB (A)	73	73	73
8.5 Drawbar/Typ DIN			-	-	-

1) See Upright Table. Contact CLARK Representative for additional lift heights 2) Specifications are given with the upright noted in line 10 3) Solid pneumatic only

4) Reduces capacity, contact factory 5) Drawbar pull and Gradeability ratings are calculated values

6) Listed values indicate motor performance. A value of 0.6 was assumed for the coefficient of traction. Actual gradeability may be limited by grade clearance

7) Loaded axle weights are based on 24" load center for English units and 500 mm for metric

ELECTRIC RIDERS

All values shown are for standard lift truck with standard equipment. If the truck is supplied with options, values may change. All values given may vary +5% and -10% due to the motor and system tolerances and represent nominal values obtained under typical operating conditions. Specifications for Non-emission limited truck.

SPECIFICATIONS

1.1 Manufacturer		CLARK	CLARK	
Characteristics	1.2 Model	TMX18	TMX20x	
	1.3 Drive	Battery	Battery	
	1.4 Operation	Seat	Seat	
	1.5 Load capacity	Q(Kg)	1800	2000
	1.6 Load center	c (mm)	500	500
	1.8 Load center distance	x (mm)	366	366
	1.9 Wheelbase	y (mm)	1340	1453
Weight	2.1 Service weight	kg	3773	3888
	2.2 Axle loading with load front/rear 7)	kg	4951/622	4951/937
	2.3 Axle loading without load front/rear 7)	kg	1807/1966	1807/2081
Tires, Chassis	3.1 Tire type 3)		SuperElastic	SuperElastic
	3.2 Tire size front		18/7/8 16 PR	18/9/12 PR
	3.3 Tire size rear		15/4.5/8	15/4.5/8
	3.5 Number of tires front/rear		2x/1	2x/1
	3.6 Track front	b10 (mm)	820	846
	3.7 Track rear	b11 (mm)	-	-
	Dimensions	4.1 Upright tilt back/forward T2/ T1	deg	6/8
4.2 Height, upright lowered		h1 (mm)	2108	2108
4.3 Free lift		h2 (mm)	110	110
4.4 Lift height 1)		h3 (mm)	3088	3088
4.5 Height, upright extended without LBR 2)		h4 (mm)	4307	4307
4.7 Height over OHG		h6 (mm)	2108	2108
4.8 Height to operator's seat		h7 (mm)	1100	1100
4.12 Height, drawbar coupling		h10 (mm)	-	-
4.19 Overall length		l1 (mm)	3000	3112
4.20 Overall length to fork face		l2 (mm)	1933	2055
4.21 Overall width		b1 (mm)	1022	1072
4.22 Std. fork size		s,e,1 (mm)	40-100-1067	40-100-1067
4.23 Carriage DIN 15173, class			ISO 2A	ISO 2A
4.24 Carriage width		b3 (mm)	940	940
4.31 Ground clearance min. with load		m1 (mm)	83	83
4.32 Ground clearance at center of wheelbase		m2 (mm)	104	104
4.33 Right angle stack aisle		(mm)	1885	1994
4.34 Process operation with palette 800x1200 (l6xb12)	Ast (mm)	-	-	
4.35 Turning radius	Wa (mm)	1519	1628	
4.36 Inner center clearance	b13 (mm)	-	-	
Performance	5.1 Travel speed with/ without load	km/ h	15/15	15/15
	5.2 Lift speed with/ without load	m/ s	0,40/0,61	0,28/0,49
	5.3 Lower speed with/ without load	m/ s	0,45/0,41	0,45/0,41
	5.5 Traction with/ without load	N	-	-
	5.6 Max. traction with/ without load	N	-	-
	5.7 Gradeability	%	-	-
	5.8 Max. gradeability with/ without load 6)	%	-	-
	5.9 Acceleration time with/ without load 5)	S	-	-
	5.10 Service brake		Disk	Disk
	Drive Line	6.1 Drive motor power (S2 - 5 min.)	KW	5,2x2
6.2 Hydr. Motor power(S3 - 15%)		KW	15,2	15,2
6.3 Battery DIN 43531/35/36 A,B,C , no.			-	-
6.4 Battery voltage and capacity		V/Ah	48/775	48/1085
6.5 Battery weight		kg	1176	1134
6.6 Max. capacity (6hr,rate 4)		kWh	43	43
8.1 Drive motor control			AV Inverter	AV Inverter
8.2 Pressure accessory equipment		bar	-	-
8.3 Amount of oil, accessory equipment		l/min	-	-
8.4 Sound level		dB (A)	73	73
8.5 Drawbar/Typ DIN			-	-

1) See Upright Table. Contact CLARK Representative for additional lift heights 2) Specifications are given with the upright noted in line 10 3) Solid pneumatic only

4) Reduces capacity, contact factory 5) Drawbar pull and Gradeability ratings are calculated values

6) Listed values indicate motor performance. A value of 0.6 was assumed for the coefficient of traction. Actual gradeability may be limited by grade clearance

7) Loaded axle weights are based on 24" load center for English units and 500 mm for metric

The CLARK TMX Series electric three-wheel lift truck is designed to handle the most demanding industrial applications. Its compact size and tight-ratio steering make it highly maneuverable. Powerful induction motors make it responsive. A large operator's compartment and un-cluttered floorboards make it easy to operate. A tight turning radius allows operation in more confined areas than four-wheel models. Capacities up to 5000 LB allow the CLARK TMX to perform where other trucks can't.

Operator Comfort / Convenience

- Low step height
- Steel step plates and grab handles on both sides
- Low-effort hydrostatic power steering
- Easy reach hand applied parking brake
- High visibility uprights
- Tilting steering pylon
- Dash display with operating and diagnostic information
- Planned Maintenance Alert

The large operator's compartment, low step height, slip-resistant steel step plates and grab handles make entry and exit from either side of the vehicle easy. The high visibility upright and longitudinal bar design of the overhead guard combine to provide optimum visibility in all directions. The TMX is equipped with a seat belt, CLARK safety wing seat and battery restraint system to help protect the operator. Lift/lower, tilt and auxiliary function levers are conveniently located on the cowl. The levers are offset from the seat centerline so the operator's right hand naturally falls on the levers. The steering wheel is offset to the left, also placing it in the correct position relative to the operator. A dash display provides continuous battery status, hour meter and a wide range of operational and diagnostic codes. A lift interrupt circuit assists in protecting the battery by disabling hydraulic operation when the battery is approximately 80% discharged. Hydraulic cushioning provides smooth, quiet staging of the upright.

AC Motors

- 100% AC system
- All motors are totally enclosed
- High torque drive motors provide high draw bar pull and gradeability

All motors used on the TMX are brushless induction motors, known for their simple yet rugged design. By eliminating brushes, CLARK has made brush changes a thing of the past and the motors no longer have to be pulled from the truck for the commutator to be turned. All motors are totally enclosed to seal out contaminants such as dust and water and are equipped with a temperature monitoring device that signals the control to cut back power should motor temperatures ever approach their limit. Thermal protection is standard on all motors, as are encoders that provide accurate speed feedback to the control. The heavy-duty drive motors produce outstanding draw bar pull (up to twice that of some competitors), allowing the TMX to ascend grades that were once only negotiable by internal combustion trucks.

Electrical Controls

- AC Traction and Pump Controls
- Drive system stall warning
- Three forms of regenerative braking: accelerator pedal release, brake pedal actuation and reversing of the directional lever
- Ramp start and controlled roll-back features
- Accurate speed control
- High acceleration rates and rapid reversal of direction possible
- Fully adjustable to meet your specific needs
- Advanced thermal protection system
- High operating efficiency

Every TMX comes standard with a hydraulic pump control and fully proportional lift. The pump motor only spins as fast as the operator requests, expending only the needed energy. All controls are sealed so they are environmentally protected and frame mounted high off the ground behind the counterweight for protection. The controls have low audible noise, improved acceleration and most importantly, increased operating time per battery charge. Being totally solid state controls, there are no forward, reverse or bypass (1A)

contactors to service or contactor tips to replace. The standard motor encoder allows vehicle speed to be accurately regulated even under varying load and operating conditions. Regenerative braking maximizes energy returned to the battery. Self diagnostic capabilities of the control and storage of status codes aid trouble shooting and minimize downtime.

Drive Line

- Reliable "plug-in" drive motor design
- Drive axle housing supports pin mounted upright for reduced lost load

"Plug-in" drive motors with heavy mounting flanges mate the splined armature shafts directly to the axle assembly for positive alignment, improved heat dissipation and reliability. The intermediate gear shaft extends inward providing an accessible location for the disc brake assemblies.

Brakes

- Responsive pre-reduction disc brake
- Long service life

The Carlisle brake system has two disc brake assemblies located externally on the inboard side of the axle housing for easy access. This design provides smooth and responsive braking as brake torque is multiplied 23.4:1. Long brake life is also a benefit. Easy reach hand parking brake mechanically actuates both service brake assemblies.

Hydraulic System

- Hydraulic valve has adjustable flow control to accommodate attachment needs
- Quick connect port allows convenient pressure check
- Continuous fluid filtration
- O-ring face seal fittings reduce leaks and are easily serviced

Continuous fluid filtration within the power steering system, a 25 micron return line filter and a 10 micron filler cap/breather combine to provide maximum filtering efficiency. The tilt cylinder's design allows intruck packing replacement.

Steering

- Quiet operation
- Full hydrostatic power steering

High maneuverability is achieved with steering angle of up to 90 degrees and proportional reversing of the inside drive wheel in tight turns. The outside drive tire powers the turn while the inside tire is powered in reverse, enhancing traction on slick or wet surfaces. The heavy-duty steer axle mount with tapered roller bearings provides high durability.

Uprights

- All-roller construction reduces friction and energy consumption
- Lateral side-thrust rollers on the fork carriage reduce friction caused by off-center loads
- Full I-section inner and intermediate rails provide maximum section strength
- Uprights accommodate 3/8 inch I.D. internal hosing for auxiliary functions requiring high flow rate
- Hydraulic cushioning on primary and secondary cylinders

CLARK standard and triple stage uprights feature nested rail construction with cylinders behind the rails giving improved operator visibility. Tilt cylinder mounts are self-aligning to minimize side loading on cylinder rods for increased seal life. Hydraulic counter-balance valve in tilt circuit is designed to prevent cavitation. Load lowering and flow limiting control valves regulate carriage lowering speed, even in the event of a line failure. ITA Class II carriages with upset forged hook type forks with retainers.